

610 Die Head – Type 2

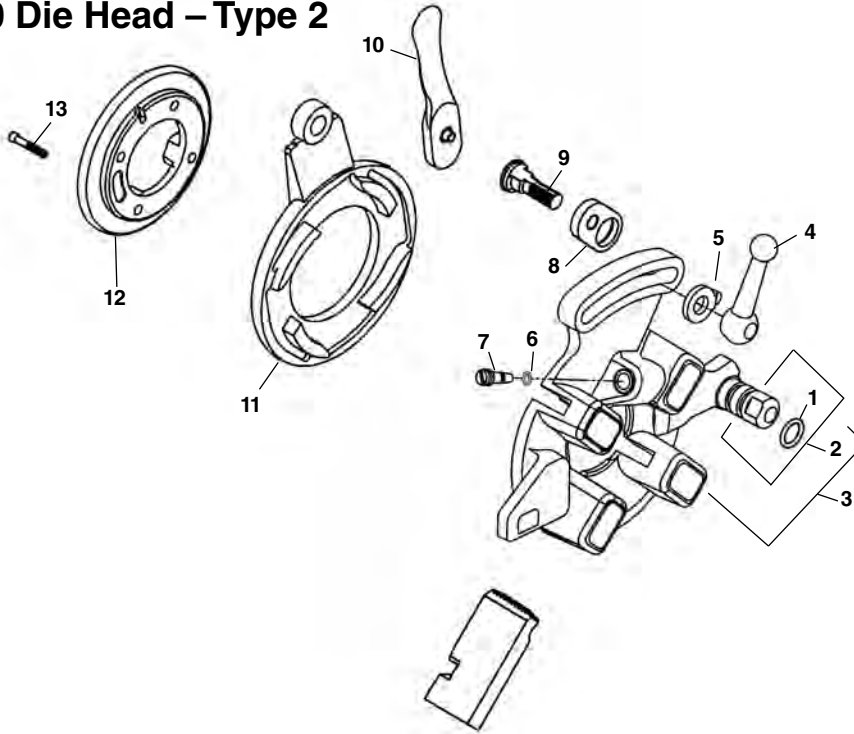

NOTE: Order parts by Catalog Number only.  
DO NOT order by Reference Number.

Ref. No.	Catalog No.	Description
—	67817	610 Die Head
1	69392	O-Ring
2	69292	Post
3	69302	Die Head Body w/Post & O-Ring
4	39970	Clamp Lever
5	26957	Washer
6	69182	O-Ring
7	69177	Needle Pin
8	39950	Throwout Link
9	39860	Lock Screw
10	46555	Throwout Lever
11	69442	Cam Plate
12	69352	Retaining Ring
13	32205	Screw 1/4" - 20 x 5/8" Socket Head (4)

354 Cutter

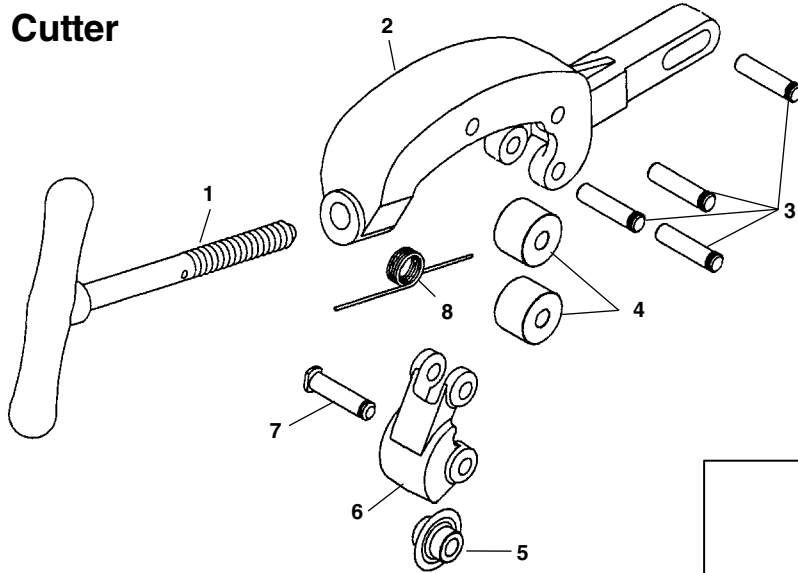

Ref. No.	Catalog No.	Description
—	68877	354 Cutter Assembly
1	69007	Feedscrew & Handle
2	69017	Cutter Frame
3	46662	Roller Pin (4)
4	34775	Roll (2)
5	33105	F3 Cutter Wheel
6	69012	Wheel Housing
7	34780	Pin & Clip
8	58617	Torsion Spring

334 Reamer

Ref. No.	Catalog No.	Description
—	68872	334 Reamer Assembly
1	68997	Screw #8-32 x 7/16" Flat Head
2	68977	Reamer Blade
3	68992	Reamer Arm w/Cone
4	39885	Wave Washer
5	68987	Clevis Pin
6	69002	3/32" x 3/4" Roll Pin

